

Ford Motor Company



EDI Implementation Documentation

INVRPT D.03A

- **Structure Chart**
- **Branching Diagram**
- **Segment Details**

FORD-WERKE GmbH

Cologne
Systems Planning & Implementation
Christopher Glogau
Tel.: ++49-221-90-13665

Issue 1.4

Issue date 30.08.2006

Ford Inventory Report

Structure / Table of Contents

Counter	No	Tag	St	MaxOcc	Level	Content
0000	1	UNB	M	1	0	Interchange header
0010	2	UNH	M	1	0	Message header
0020	3	BGM	M	1	0	Beginning of message
0040	4	DTM	M	10	1	Date/time/period
0080		SG2	C	20	1	NAD
0090	5	NAD	M	1	1	Name and address
0290		SG9	C	9999999	1	LIN-SG11
0300	6	LIN	M	1	1	Line item
0420		SG11	C	9999	2	INV-QTY-DTM
0430	7	INV	M	1	2	Inventory management related details
0440	8	QTY	M	1	3	Quantity
0470	9	DTM	C	5	3	Date/time/period
0730	10	UNT	M	1	0	Message trailer
0000	11	UNZ	M	1	0	Interchange trailer

Counter = Counter of segment/group within the EDIFACT standard

No = Consecutive segment number

MaxOcc = Maximum occurrence of the segment/group

St = Status

EDIFACT: M=Mandatory, C=Conditional

User specific: R=Required, O=Optional, D=Dependent,

A=Advised, N=Not used

Branching Diagram of Used Segments/Groups

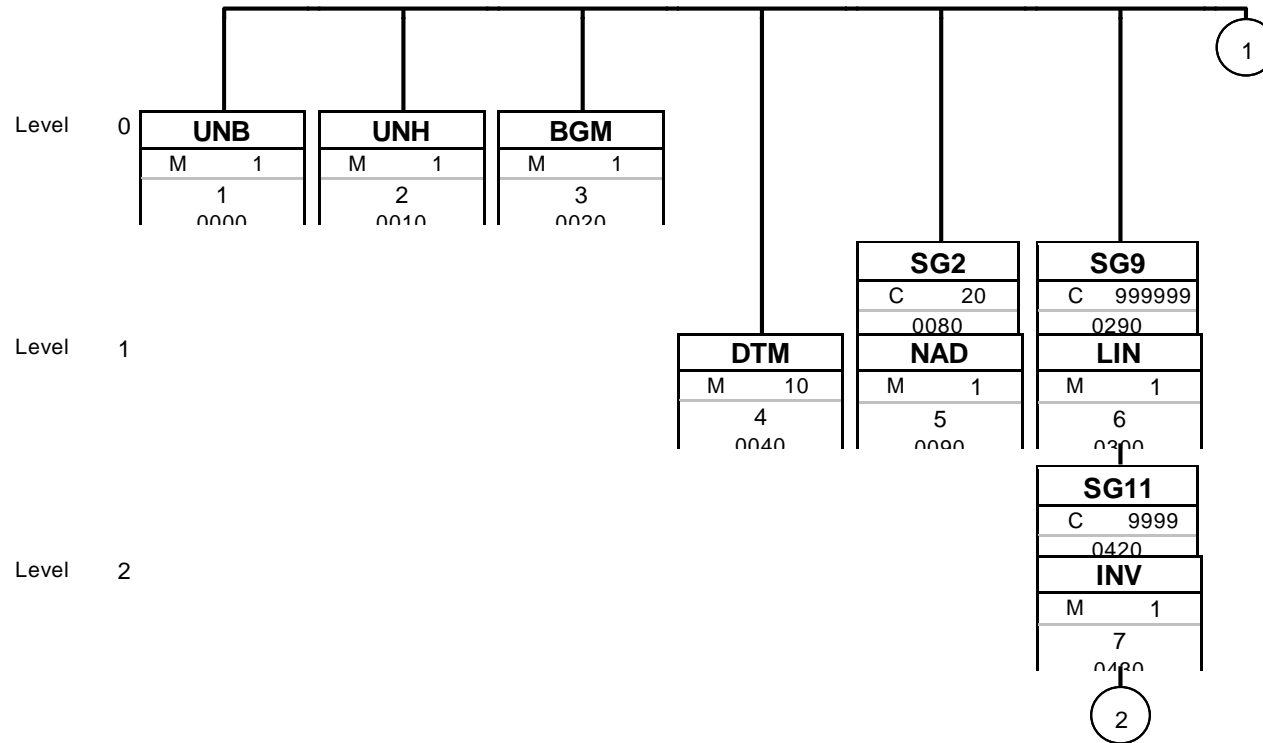

Tag
St MaxOcc
No
Counter

Tag = Segment/Group Tag
 St = Status (M=Mandatory, C=Conditional, R=Required, O=Optional, A=Advised, D=Dependent)
 MaxOcc = Maximum occurrence of the segment/group
 No = Consecutive segment number
 Counter = Counter of segment/group within the EDIFACT standard

Branching Diagram of Used Segments/Groups

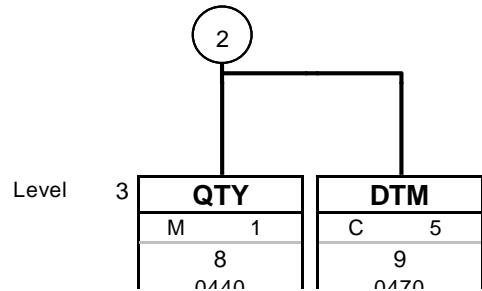

Tag
St MaxOcc
No
Counter

Tag = Segment/Group Tag
 St = Status (M=Mandatory, C=Conditional, R=Required, O=Optional, A=Advised, D=Dependent)
 MaxOcc = Maximum occurrence of the segment/group
 No = Consecutive segment number
 Counter = Counter of segment/group within the EDIFACT standard

Branching Diagram of Used Segments/Groups

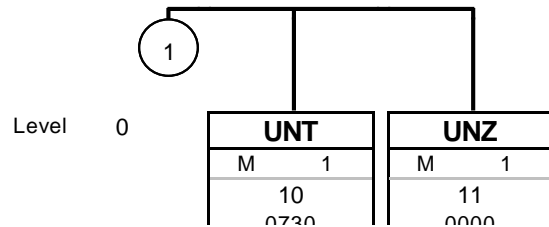

Tag
St MaxOcc
No
Counter

Tag = Segment/Group Tag
 St = Status (M=Mandatory, C=Conditional, R=Required, O=Optional, A=Advised, D=Dependent)
 MaxOcc = Maximum occurrence of the segment/group
 No = Consecutive segment number
 Counter = Counter of segment/group within the EDIFACT standard

Ford Inventory Report

Segments

Counter	No	Tag	St	MaxOcc	Level	Name
0000	1	UNB	M	1	0	Interchange header

		Standard	Implementation		
Tag	Name	St Format	St Format	Usage / Remark	
S001	Syntax identifier	M	M		
0001	Syntax identifier	M a4	M a4	UNOC UNECE level C	
0002	Syntax version number	M n1	M n1	3 Version 3	
S002	Interchange sender	M	M		
0004	Sender identification	M an..35	M an..35	Sender's GSDB Code	
0007	Partner identification code qualifier	C an..4	C an..4	92 Assigned by buyer or buyer's agent	
0008	Address for reverse routing	C an..14	N	Not used	
S003	Interchange recipient	M	M		
0010	Recipient identification	M an..35	M an..35	Receiver's GSDB Code	
0007	Partner identification code qualifier	C an..4	C an..4	92 Assigned by buyer or buyer's agent	
0014	Routing address	C an..14	N	Not used	
S004	Date/time of preparation	M	M		
0017	Date of preparation	M n6	M n6		
0019	Time of preparation	M n4	M n4		
0020	Interchange control reference	M an..14	M an..14		
S005	Recipient's reference, password	C	N		
0022	Recipient's reference/password	M an..14	N	Not used	
0025	Recipient's reference/password qualifier	C an2	N	Not used	
0026	Application reference	C an..14	N	Not used	
0029	Processing priority code	C a1	N	Not used	
0031	Acknowledgement request	C n1	N	Not used	
0032	Communications agreement ID	C an..35	N	Not used	
0035	Test indicator	C n1	N	Not used	

Remark:

UNB+UNOC:3+ABCDE:92+0134A:92+051209:1000+987654321'

No = Consecutive segment number
 MaxOcc = Maximum occurrence of the segment/group
 Counter = Counter of segment/group within the EDIFACT standard

St = Status
 EDIFACT: M=Mandatory, C=Conditional
 User specific: R=Required, O=Optional, D=Dependent, A=Advised, N=Not used

Ford Inventory Report

Segments

Counter	No	Tag	St	MaxOcc	Level	Name
0010	2	UNH	M	1	0	Message header

Standard			Implementation	
Tag	Name	St Format	St Format	Usage / Remark
0062	Message reference number	M an..14	M an..14	
S009	Message identifier	M	M	
0065	Message type	M an..6	M an..6	INVRPT Inventory report message
0052	Message version number	M an..3	M an..3	D Draft version/UN/EDIFACT Directory
0054	Message release number	M an..3	M an..3	03A Release 2003 - A
0051	Controlling agency	M an..2	M an..2	UN UN/CEFACT
0057	Association assigned code	C an..6	N	Not used
0068	Common access reference	C an..35	N	Not used
S010	Status of the transfer	C	N	
0070	Sequence of transfers	M n..2	N	Not used
0073	First and last transfer	C a1	N	Not used

Remark:

UNH+123456789+INVRPT:D:03A:UN'

No = Consecutive segment number
 MaxOcc = Maximum occurrence of the segment/group
 Counter = Counter of segment/group within the EDIFACT standard

St = Status
 EDIFACT: M=Mandatory, C=Conditional
 User specific: R=Required, O=Optional, D=Dependent, A=Advised, N=Not used

Ford Inventory Report

Segments

Counter	No	Tag	St	MaxOcc	Level	Name
0020	3	BGM	M	1	0	Beginning of message

Standard			Implementation	
Tag	Name	St Format	St Format	Usage / Remark
C002	Document/message name	C	C	
1001	Document name code	C an..3	C an..3	35 Inventory report
1131	Code list identification code	C an..17	N	Not used
3055	Code list responsible agency code	C an..3	N	Not used
1000	Document name	C an..35	C an..35	INVRPT
C106	Document/message identification	C	C	
1004	Document identifier	C an..35	C an..35	Document number
1056	Version identifier	C an..9	N	Not used
1060	Revision identifier	C an..6	N	Not used
1225	Message function code	C an..3	C an..3	9 Original
4343	Response type code	C an..3	N	Not used

Remark:

BGM+35:::INVRPT+123456789+9'

No = Consecutive segment number
 MaxOcc = Maximum occurrence of the segment/group
 Counter = Counter of segment/group within the EDIFACT standard

St = Status
 EDIFACT: M=Mandatory, C=Conditional
 User specific: R=Required, O=Optional, D=Dependent, A=Advised, N=Not used

INVRPT / UN D.03A

Revised by: Christopher Glogau - printed copies are uncontrolled

Date: 30.08.2006

Page 8 of 17

Ford Inventory Report

Segments

Counter	No	Tag	St	MaxOcc	Level	Name
0040	4	DTM	M	10	1	Date/time/period

Standard			Implementation	
Tag	Name	St Format	St Format	Usage / Remark
C507	Date/time/period	M	M	
2005	Date or time or period function code qualifier	M an..3	M an..3	137 Document/message date/time
2380	Date or time or period text	C an..35	C an..35	
2379	Date or time or period format code	C an..3	C an..3	102 CCYYMMDD

Remark:

DTM+137:20051109:102'

No = Consecutive segment number
 MaxOcc = Maximum occurrence of the segment/group
 Counter = Counter of segment/group within the EDIFACT standard

St = Status
 EDIFACT: M=Mandatory, C=Conditional
 User specific: R=Required, O=Optional, D=Dependent, A=Advised, N=Not used

Ford Inventory Report

Segments

Counter	No	Tag	St	MaxOcc	Level	Name
0080		SG2	C	20	1	NAD
0090	5	NAD	M	1	1	Name and address

Standard			Implementation		
Tag	Name	St Format	St Format	Usage / Remark	
3035	Party function code qualifier	M an..3	M an..3	SF Ship from ST Ship to WH Warehouse keeper	
C082	Party identification details	C	C		
3039	Party identifier	M an..35	M an..35	GSDB Code of ship to, ship from and warehouse keeper. All three GSDB codes must be present.	
1131	Code list identification code	C an..17	N	Not used	
3055	Code list responsible agency code	C an..3	C an..3	92 Assigned by buyer or buyer's agent	
C058	Name and address	C	N		
3124	Name and address description	M an..35	N	Not used	
3124	Name and address description	C an..35	N	Not used	
3124	Name and address description	C an..35	N	Not used	
3124	Name and address description	C an..35	N	Not used	
3124	Name and address description	C an..35	N	Not used	
C080	Party name	C	N		
3036	Party name	M an..35	N	Not used	
3036	Party name	C an..35	N	Not used	
3036	Party name	C an..35	N	Not used	
3036	Party name	C an..35	N	Not used	
3036	Party name	C an..35	N	Not used	
3045	Party name format code	C an..3	N	Not used	
C059	Street	C	N		
3042	Street and number or post office box identifier	M an..35	N	Not used	
3042	Street and number or post office box identifier	C an..35	N	Not used	
3042	Street and number or post office box identifier	C an..35	N	Not used	
3042	Street and number or post office box identifier	C an..35	N	Not used	

No = Consecutive segment number
 MaxOcc = Maximum occurrence of the segment/group
 Counter = Counter of segment/group within the EDIFACT standard

St = Status
 EDIFACT: M=Mandatory, C=Conditional
 User specific: R=Required, O=Optional, D=Dependent, A=Advised, N=Not used

Ford Inventory Report

Segments

		Standard	Implementation	
Tag	Name	St Format	St Format	Usage / Remark
3164	City name	C an..35	N	Not used
C819	Country sub-entity details	C	N	
3229	Country sub-entity name code	C an..9	N	Not used
1131	Code list identification code	C an..17	N	Not used
3055	Code list responsible agency code	C an..3	N	Not used
3228	Country sub-entity name	C an..70	N	Not used
3251	Postal identification code	C an..17	N	Not used
3207	Country name code	C an..3	N	Not used

Remark:

NAD+SF+ABCDE::92'

No = Consecutive segment number
 MaxOcc = Maximum occurrence of the segment/group
 Counter = Counter of segment/group within the EDIFACT standard

St = Status
 EDIFACT: M=Mandatory, C=Conditional
 User specific: R=Required, O=Optional, D=Dependent, A=Advised, N=Not used

Ford Inventory Report

Segments

Counter	No	Tag	St	MaxOcc	Level	Name
0290		SG9	C	9999999	1	LIN-SG11
0300	6	LIN	M	1	1	Line item

Standard			Implementation	
Tag	Name	St Format	St Format	Usage / Remark
1082	Line item identifier	C an..6	C an..6	Numerical line identifier, starting at and incrementing by 1.
1229	Action request/notification description code	C an..3	N	Not used
C212	Item number identification	C	C	
7140	Item identifier	C an..35	C an..35	Enter Ford part number here. Prefix, base and suffix of the part number have to be separated by hyphens (see example below), no blanks allowed.
7143	Item type identification code	C an..3	C an..3	BH Part number
1131	Code list identification code	C an..17	N	Not used
3055	Code list responsible agency code	C an..3	C an..3	92 Assigned by buyer or buyer's agent
C829	Sub-line information	C	N	
5495	Sub-line indicator code	C an..3	N	Not used
1082	Line item identifier	C an..6	N	Not used
1222	Configuration level number	C n..2	N	Not used
7083	Configuration operation code	C an..3	N	Not used.

Remark:

Use only one LIN segment per part number. It is not allowed to repeat a LIN segment with a part number that has already been used before in the same message.

LIN+1++96AG-B1306-AA:BH::92'

No = Consecutive segment number
 MaxOcc = Maximum occurrence of the segment/group
 Counter = Counter of segment/group within the EDIFACT standard

St = Status
 EDIFACT: M=Mandatory, C=Conditional
 User specific: R=Required, O=Optional, D=Dependent, A=Advised, N=Not used

Ford Inventory Report

Segments

Counter	No	Tag	St	MaxOcc	Level	Name
0420		SG11	C	9999	2	INV-QTY-DTM
0430	7	INV	M	1	2	Inventory management related details

Standard			Implementation	
Tag	Name	St Format	St Format	Usage / Remark
4501	Inventory movement direction code	C an..3	N	Not used
7491	Inventory type code	C an..3	N	Not used
4499	Inventory movement reason code	C an..3	N	Not used
4503	Inventory balance method code	C an..3	C an..3	3 Interim inventory balance
C522	Instruction	C	N	
4403	Instruction type code qualifier	M an..3	N	Not used
4401	Instruction description code	C an..3	N	Not used
1131	Code list identification code	C an..17	N	Not used
3055	Code list responsible agency code	C an..3	N	Not used
4400	Instruction description	C an..35	N	Not used

Remark:

This segment is only utilised to enable the subsequent QTY & DTM sections to be included.

INV++++3'

No = Consecutive segment number
 MaxOcc = Maximum occurrence of the segment/group
 Counter = Counter of segment/group within the EDIFACT standard

St = Status
 EDIFACT: M=Mandatory, C=Conditional
 User specific: R=Required, O=Optional, D=Dependent, A=Advised, N=Not used

Ford Inventory Report

Segments

Counter	No	Tag	St	MaxOcc	Level	Name
0420		SG11	C	9999	2	INV-QTY-DTM
0440	8	QTY	M	1	3	Quantity

Standard			Implementation	
Tag	Name	St Format	St Format	Usage / Remark
C186	Quantity details	M	M	
6063	Quantity type code qualifier	M an..3	M an..3	66 Committed quantity 145 Actual stock 198 Quantity in transit 248 Reserved quantity 256 At warehouse within 24hrs
6060	Quantity	M an..35	M an..35	
6411	Measurement unit code	C an..8	M an..8	KGM kilogram PCE pieces

Remark:

- 66 Committed quantity has to be a corresponding DTM segment (see next page) specifying the promise date. Has to be repeated for each promise quantity.
- 145 Actual stock This qualifier is mandatory
- 198 Quantity in transit has to be a corresponding DTM segment (see next page) specifying the expected arrival date at the warehouse. Has to be repeated for each in transit quantity
- 248 Reserved quantity This qualifier indicates blocked material and is mandatory if blocked material is present.
- 256 At warehouse within 24h material that could be made available within 24hrs in case of shortages.

QTY+145:10000:KGM'

QTY+198:5000:KGM'

QTY+248:2000:KGM'

No = Consecutive segment number
 MaxOcc = Maximum occurrence of the segment/group
 Counter = Counter of segment/group within the EDIFACT standard

St = Status
 EDIFACT: M=Mandatory, C=Conditional
 User specific: R=Required, O=Optional, D=Dependent, A=Advised, N=Not used

Ford Inventory Report

Segments

Counter	No	Tag	St	MaxOcc	Level	Name
0420		SG11	C	9999	2	INV-QTY-DTM
0470	9	DTM	C	5	3	Date/time/period

Standard			Implementation	
Tag	Name	St Format	St Format	Usage / Remark
C507	Date/time/period	M	M	
2005	Date or time or period function code qualifier	M an..3	M an..3	69 Delivery date/time, promised for
2380	Date or time or period text	C an..35	C an..35	
2379	Date or time or period format code	C an..3	C an..3	102 CCYYMMDD

Remark:

This segment is only used (and in that case mandatory) when the previous QTY segment qualifier is '66' or '198'. If QTY qualifier is '198', the DTM specifies the expected date of arrival of the material in transit at the warehouse.

DTM+69:20060715:102'

No = Consecutive segment number
 MaxOcc = Maximum occurrence of the segment/group
 Counter = Counter of segment/group within the EDIFACT standard

St = Status
 EDIFACT: M=Mandatory, C=Conditional
 User specific: R=Required, O=Optional, D=Dependent, A=Advised, N=Not used

Ford Inventory Report

Segments

Counter	No	Tag	St	MaxOcc	Level	Name
0730	10	UNT	M	1	0	Message trailer

		Standard	Implementation	
Tag	Name	St Format	St Format	Usage / Remark
0074	Number of segments in the message	M n..6	M n..6	
0062	Message reference number	M an..14	M an..14	

Remark:

UNT+9+123456789'

No = Consecutive segment number
 MaxOcc = Maximum occurrence of the segment/group
 Counter = Counter of segment/group within the EDIFACT standard

St = Status
 EDIFACT: M=Mandatory, C=Conditional
 User specific: R=Required, O=Optional, D=Dependent, A=Advised, N=Not used

Segments

Counter	No	Tag	St	MaxOcc	Level	Name
0000	11	UNZ	M	1	0	Interchange trailer

Standard			Implementation	
Tag	Name	St Format	St Format	Usage / Remark
0036	Interchange control count	M n..6	M n..6	
0020	Interchange control reference	M an..14	M an..14	

Remark:

UNZ+1+987654321'

No = Consecutive segment number
 MaxOcc = Maximum occurrence of the segment/group
 Counter = Counter of segment/group within the EDIFACT
 standard

St = Status
 EDIFACT: M=Mandatory, C=Conditional
 User specific: R=Required, O=Optional, D=Dependent,
 A=Advised, N=Not used